

HAPPY BUCCANEER

LIFTING HEAVY
CARGO FOR
WORLDWIDE
TRANSPORT

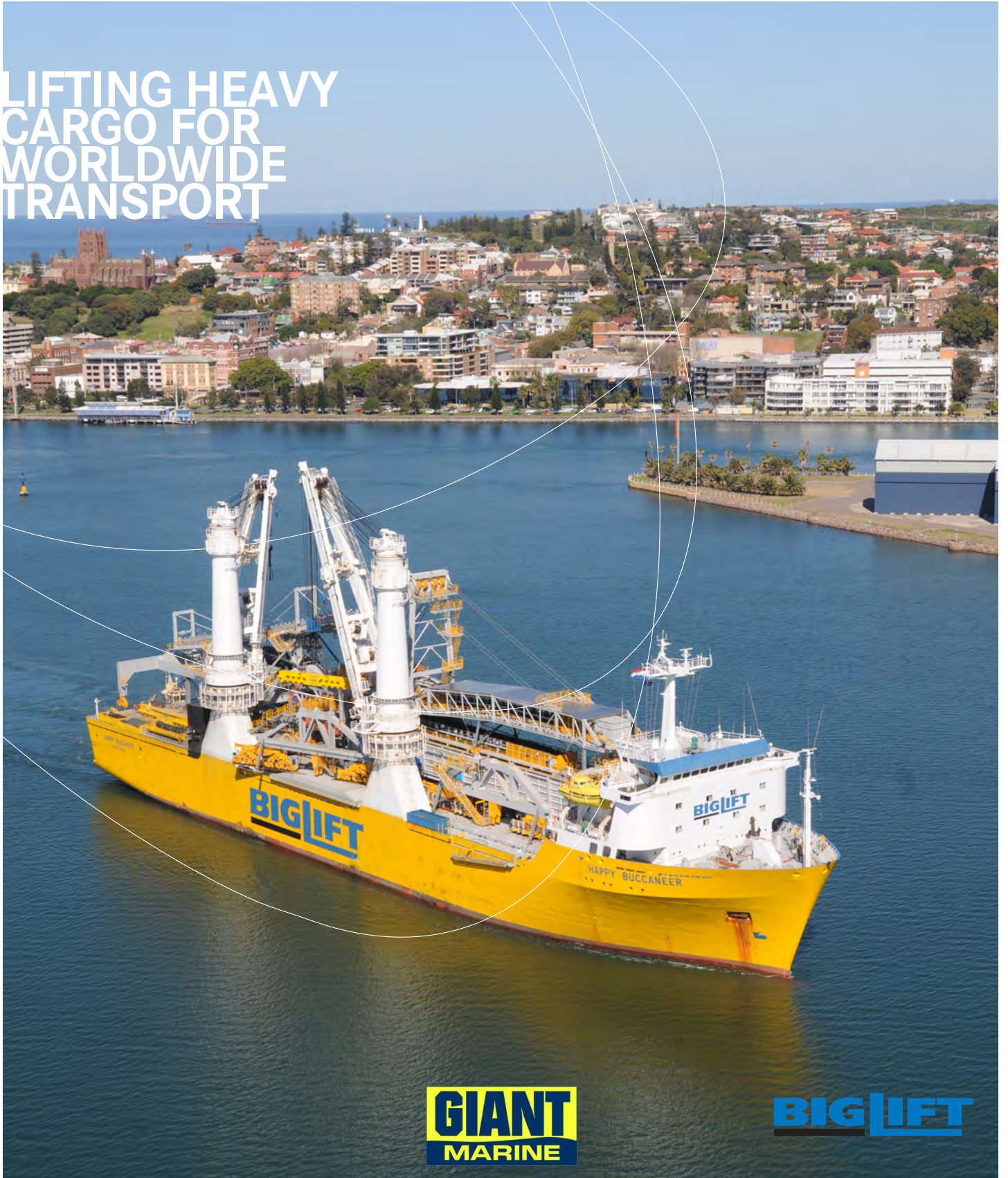

GIANT
MARINE

BIGLIFT

HAPPY BUCCANEER

HATCH OPENINGS AND ALLOWABLE LOADS

HATCH OPENINGS

Weather deck	110.5 x 20.6 m
Tween deck	67.0 x 20.0 m

ALLOWABLE LOADS

Weather deck hatch covers	15.0 t/m ²
Tween deck hatch covers	15.0 t/m ²
Tank top	15.0 t/m ²

FLOOR SPACE

Weather deck	3,067 m ²
Tween deck	2,275 m ²
Tank top	1,344 m ²

CRANES

2 x 700 mt SWL

COMBINABLE

1400 mt

TROLLEY

25 mt SWL

PRINCIPAL DIMENSIONS

Length overall	145.89 m
Length p.p.	134.00 m
Breadth moulded	28.30 m
Breadth extreme	28.43 m

Summer draft	8.24 m
Draft open sailing	7.02 m

REGISTRATION

The Netherlands

CLASS

LRS X100A1 XLMC UMS
strengthened for
heavy cargoes

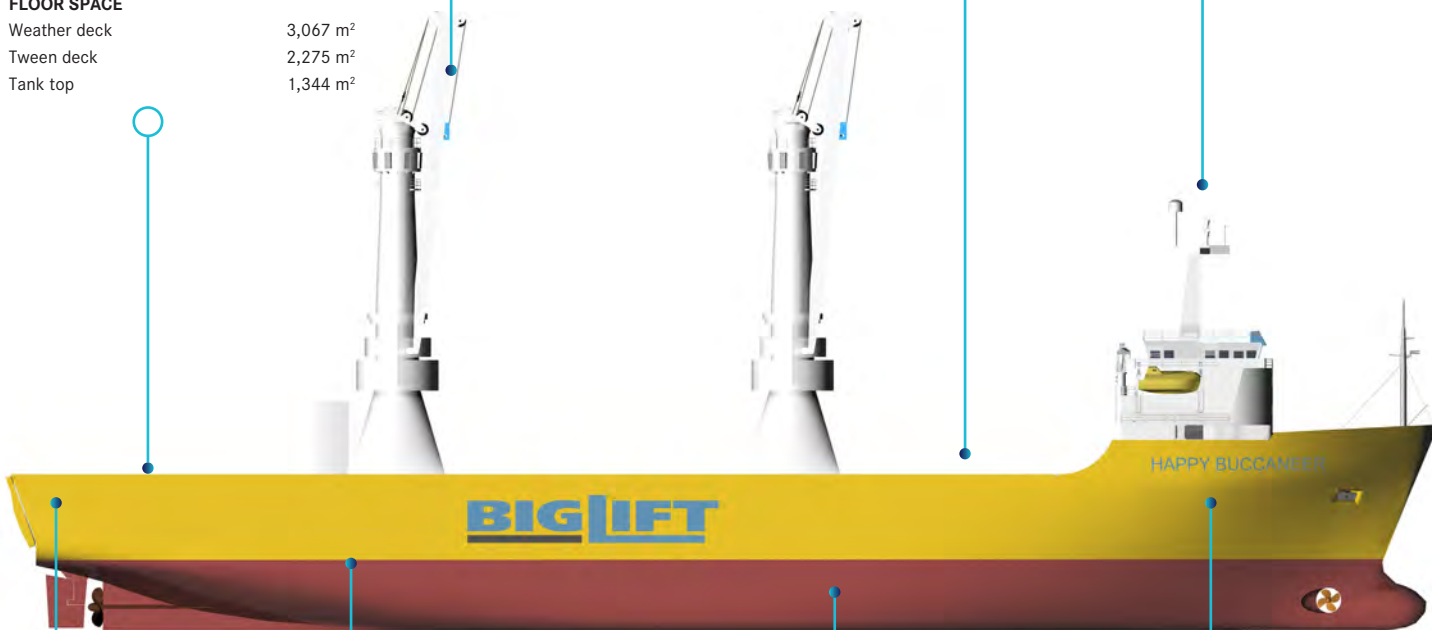

RAMP

Position	stern
Dimensions	20.3 x 7.6 m
Capacity	2,500 mt

MAIN ENGINE

Hitachi Sulzer	2 sets 3840 kW
Bowthruster	750 kW
Service speed	14.75 kn at draft 6.00 m

CAPACITY

Lower hold	7,517 m ³
Tween deck	12,391 m ³

DEADWEIGHT

At Summer (sea water) draft
13,740 mton inc. tween deck
hatch covers, pillars

HAPPY BUCCANEER

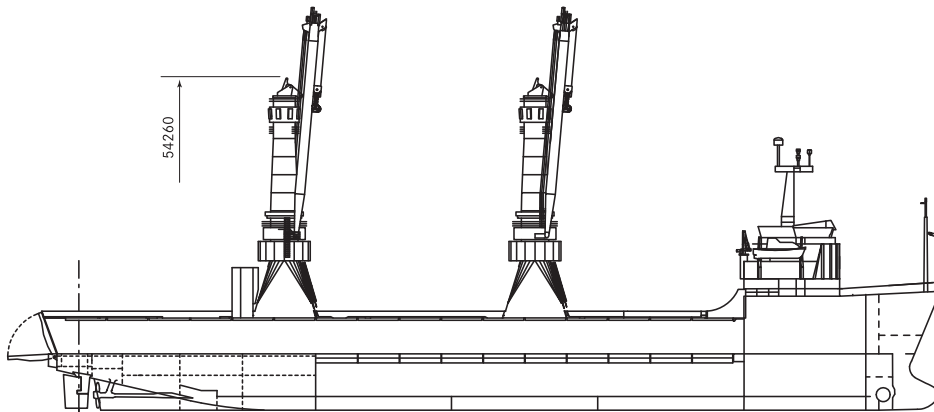

Side View

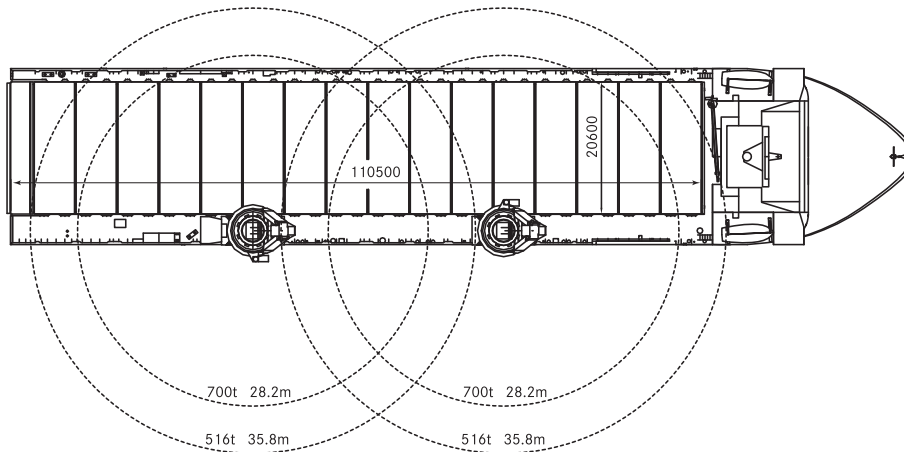

Weatherdeck

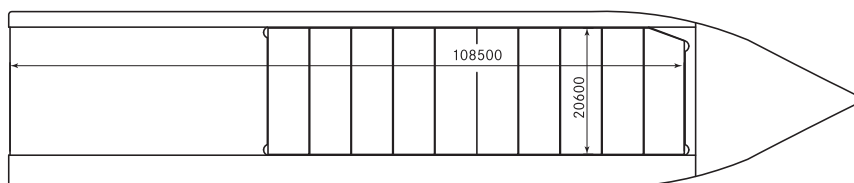

Tweendeck

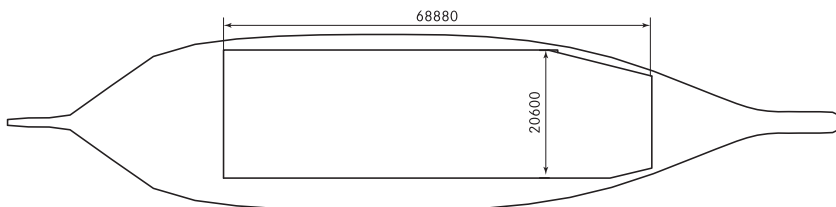

Tanktop

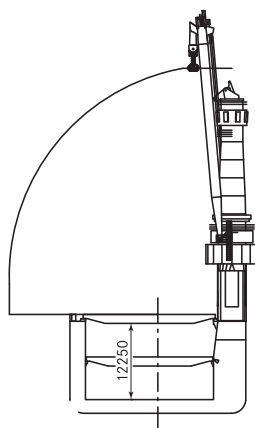

Cross section

HAPPY BUCCANEER

Class	LRS ✕ 100 A1 ✕ LMC UMS			
Principal Dimensions	Length overall	145.89 m		
	Length p.p.	134.00 m		
	Breadth moulded	28.30 m		
	Breadth extreme	28.43 m		
	Summer draft	8.24 m		
	Draft "open sailing"	7.02 m		
Deadweight	Summer (sea water)	13,740 mton		
Tonnage		International	Panama	Suez
	GT	16,341	16,352	16,081
	NT	4,902	13,473	12,642
Capacity	Lowerhold	7,517 m ³		
	Tween deck	12,391 m ³		
Floor space	Weather deck	3,067 m ²		
	Tween deck	2,275 m ²		
	Tank top	1,344 m ²		
Hatch openings	Weather deck	110.5 x 20.6 m		
	Tween deck	67.0 x 20.0 m		
Heights	Tween deck	5.38 m		
	Lower hold	5.42 m		
	Total hold	12.25 m		
Allowable loads	Weather deck hatch covers	5.0 t/m ²		
	with pillars	15.0 t/m ²		
	Tween deck hatch covers	5.0 t/m ²		
	with pillars	15.0 t/m ²		
	Tank top	15.0 t/m ²		
Cranes	Combinable	1,400 mt	SWL	
	Situated on starboard side	2 x 700 mt	SWL	
	Fitted with trolley	2 x 25 mt	SWL	
Ramp	Position	stern		
	Dimensions	20.3 x 7.6 m		
	Capacity	2,500 mt		
	Working height	2 - 3.5 m		
Main engine	2 x Hitachi Sulzer 6ZAL 40	2 x 3,840 kW		
	Bowthruster	760 kW		
	Service speed	14.75 kN	at draft 6.00 m	
Container capacity	1,050 TEU			

HAPPY BUCCANEER

Happy Buccaneer Amsterdam The Netherlands 1984

These particulars are believed to be correct, but without guarantee, and they must not be used as basis for Charter Parties or contracts without Owners' explicit written authority.

BIGLIFT

**GIANT
MARINE**

Giant Marine - General Agent for BigLift Shipping BV
13, Rue Séguier - 75006 Paris - France
Tel: +33 1 39 63 37 37 - Email: info@giantmarine.com